

HST LED-LUMINAIRE

Product number: **43 071 83** (3,1W) / **43 071 86** (6,3W)

Input 220-240V Opal globe , IP67 , AISI316L

Thanks to its sturdy construction, the luminaire is suited for use in wet areas in industry and sites where there is a significant danger of breakage. The globe is made from impact-resistant polycarbonate and is mounted with four screws.

Opal globe. The globes are also available as colored or with text labels.

The luminaire can be chain-connected

3D CAD models available, e.g. IGS. and STEP files.

INPUT VOLTAGE	220-240V
ENCLOSURE CLASS	IP 67
TEMPERATURE RANGE	-25 °C - + 70 °C (Continuous)
CONNECTORS	Terminal block 4mm ² + protective earth
LAMP SOCKET	Inbuilt Led-module
WEIGHT	1,3 kg net
CABLE GLAND	2x M20 IP 68 Cableglands Ø 7-13mm
LIGHT DISTRIBUTION	3,1W= 390Lm / 6,3W = 740Lm
COLOR TEMPERATURE	4000K
VIBRATION	IEC 60068-2-6, Test Fc: Vibration (sinusoidal) / HODK0001
COUNTRY OF ORIGIN	Finland
MODELS	For varying globecolor and configurations, please ask for more information or visit www.selcast.fi (available in English).
CERTIFICATION	CE: Certificated according to the standard; EN60598-2-1:1989, EN 60598-1:2008+A11:2009, EN 62493:2010, EN 62471:2008



3,1W 390 lm

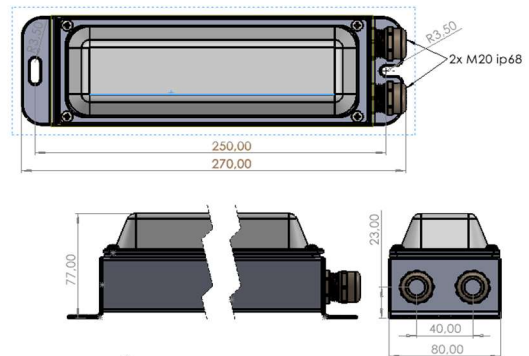

6,3W 740 lm

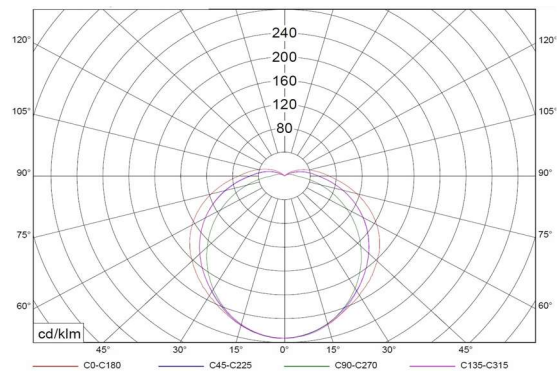
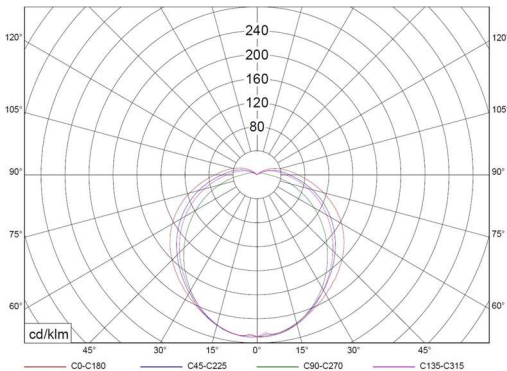

We reserve the right to make technical and design changes to the product

OSOITE	ADDRESS	PUHELIN/PHONE	TELEFAX	E-MAIL	KOTIPAIKKA	Y-TUNNUS
Kilantie 19	Kilantie 19	019-278 5800	019-278 5811	selcast@selcast.fi	REGISTRED	0728634-7
PL 36	BOX 36	+ 358 19 278 5800	+ 358 19 278 5811	HOME PAGE	Karjaa	VAT-NUMBER
10301 Karjaa	FI-10301 Karjaa			www.selcast.fi		FI07286347